

Great news for **BRACKETT** Circular Padder Owners !

Now you can Upgrade your Brackett “C.P.” in your own plant !!

As a Circular Padder user, you are already aware of the benefits of having a **Brackett** Circular Padder in your shop. Now you can expand the capabilities of your machine with a field retrofit built by **Brackett**, which gives your C.P. the ability to reliably handle coated enamel stock with the addition of a “roughing” unit. Built specifically for YOUR Circular Padder, the **Brackett** Rougher unit will integrate seamlessly with the operation of your machine without inhibiting the usual high-speed production you expect from the Brackett Circular Padder.

This field retrofit comes with everything you need including genuine Brackett parts, full installation and set-up documentation, additional guards for operator safety and, of course, the full support of your **Brackett** Service Department.

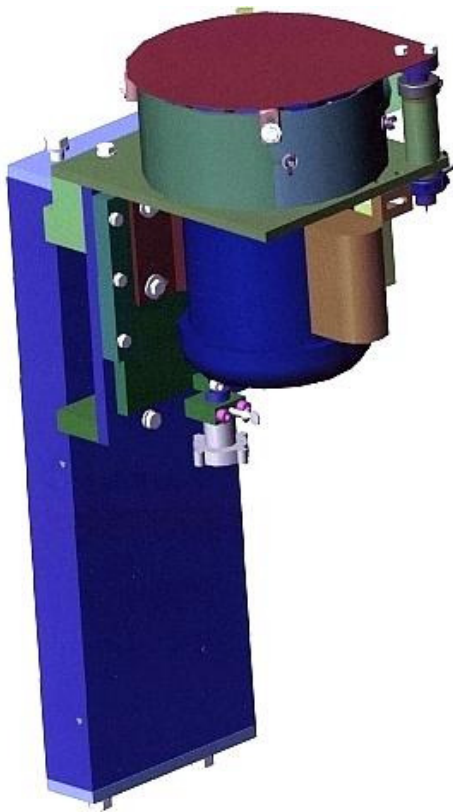

Pre-assembled Unit



Mounted and ready for WORK !

Once installed, the rougher doesn't change the operation of your machine. It can be left turned off, and then called upon with the flip of a switch as needed. While in operation, the unit performs a light slitting action on the spine of the pad before it passes over the hot melt glue pot, thereby increasing the glue's ability to penetrate the material. This greatly improves the holding ability of your padding glue when making pads from coated or enamel stock. A vacuum unit is included to remove the paper dust as the pads are being "roughed".

To add this extra *"punch"* to an already valuable piece of production equipment, click to order **Brackett's** Rougher field modification – or call our service / sales department if you need further information.



Brackett Inc.

P.O. Box 19306

Topeka, KS 66619

(800)-255-3506 (785)-862-2205

FAX (785)-862-1127

E-Mail: brackett@brackett-inc.com

Internet: www.brackett-inc.com